

# Implementing a Line Frequency Meter

## Introduction

The circuits illustrated below can be used to measure an ac line frequency using the LM2917 frequency-to-voltage converter and DATEL's DMS Series digital voltmeters. The circuit in Figure 1 is used to provide isolation from the ac line. The transformer is a step-down type with a secondary voltage of 6.3Vrms. This voltage is rectified and applied to the resistive voltage divider consisting of R7 and R8. Figure 2 depicts the resulting waveform seen at the junction of R7 and R8. This voltage ( $F_{IN}$ ), which will have a peak of approximately 1 Volt, is then applied to the input (pin 1) of the LM2917.

The circuit in Figure 3 will have a display reading of 60.0 for an input frequency of 60Hz. The 0.047 $\mu$ F capacitor (C1) should be a polyester type. The 47 $\mu$ F capacitor (C2) is used to reduce the output ripple of the LM2917. If the value of C2 is made too large, the ripple will be further reduced, however, the response time of the output for a given change in  $F_{IN}$  will take longer to reach its final value.

The 5k $\Omega$  potentiometer is a multi-turn type that allows for calibration between 50 to 60Hz. All other resistors should be precision, metal-film types with good temperature stability.

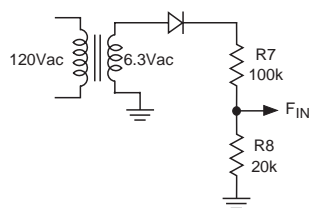

Figure 1. Input Isolation and Step Down

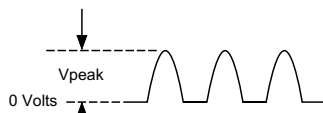

Figure 2.  $F_{IN}$  Waveform

## Theory of Operation

The following equation is used to determine the output voltage (pin 3) of the LM2917:

$$V_{OUT} = (R1 + R2) (V_{CC}) (C1) (F_{IN})$$

$$V_{OUT} = (25500 + 2850) (7.5) (47 \times 10^{-9}) (60)$$

$$V_{OUT} = 0.6 \text{ Volts}$$

The value of  $V_{CC}$  used in the above equation is +7.5 Volts. This is due to the zener diode internal to the LM2917. The value for R2 is its adjusted value. It is used in the above equation for simplicity. The 0.6 Volts is applied to pin 11 ((+) INPUT HI) of the DMS meter.

With the meter configured as shown, the display reading for an input of 0.6V will be 60.0. R2 is adjusted as necessary until the desired display reading is obtained for a given input frequency to the LM2917.

## Further Reading

The LM2917 is an extremely versatile frequency-to-voltage converter IC. Its recommended source is National Semiconductor. Many more useful applications using the LM2917 can be found in National Semiconductor's Linear Applications Handbook, specifically in Application Note 162 (AN-162).

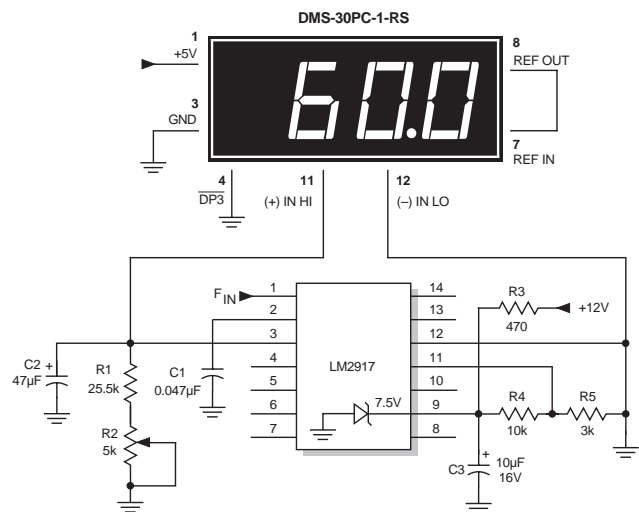

Figure 3. Line Frequency Meter