



Featuring Murata Power Solutions' ultra-wide, 18-72V, input voltage range, this Family of A-Series, TWR (triple-output) DC/DC converters deliver up to 15 Watts.

PRODUCT OVERVIEW

These devices each have a primary +5V output that can source from 1 Amp to 1.5 Amps (model dependent) and auxiliary $\pm 12/15V$ outputs that can source from ± 150 to $\pm 250mA$ (model dependent). All models can simultaneously source maximum rated current from both primary and auxiliary outputs. The nominal input voltage for each model is 48V.

As members of Murata Power Solutions' new A-Series, the 12-15W triples exhibit both low cost and outstanding long-term reliability. Their design combines straightforward circuit topologies, proven SMT-on-pcb construction methods, the newest components, and highly repeatable automatic-assembly techniques. The A-Series TWR's superior durability is substantiated by a rigorous in-house

qualification program that includes HALT (Highly-Accelerated Life Testing), which is designed to detect any potential electrical, mechanical or process weakness.

Packaged in standard, 2" x 2" x 0.45", shielded metal cases with non-conductive coatings, these fully isolated (1000Vdc minimum) DC/DC's offer excellent line and load regulation. Additionally, these A-Series triples have non-latching output current limiting, input overvoltage shutdown, input reverse-polarity protection, and output overvoltage clamping to protect both the power converters and their loads. All A-Series TWR models are fully EMI characterized and designed to meet UL1950, IEC 950, CSA 950 and EN60950.

FEATURES

- Low cost! Highly Reliable!
- Output voltages: +5V/ $\pm 12V$ or +5V/ $\pm 15V$
- Ultra-wide, 18-72V, input voltage ranges
- Small, 2" x 2" x 0.45" packages
- Guaranteed efficiencies to 80%
- Fully isolated, 1500Vdc guaranteed
- -40 to +100°C operating temperature
- Proven SMT-on-pcb construction
- Shielded (5-side) metal cases with insulated baseplates
- Designed to meet UL 1950 and EN60950
- Qual Tested; HALT tested; EMC tested
- Modifications and customs for OEM's

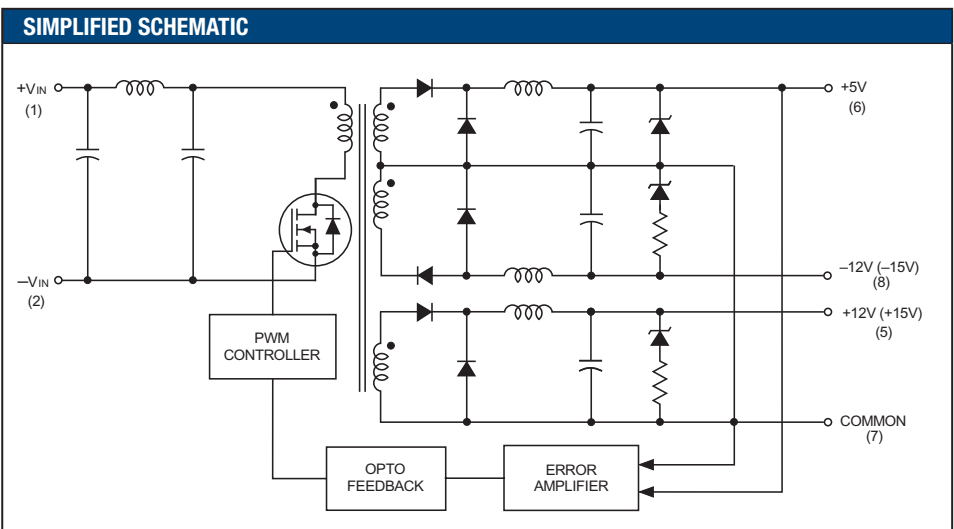

Typical topography is shown.



PERFORMANCE SPECIFICATIONS AND ORDERING GUIDE ①												
Model	Output						Input			Efficiency		Package (Case/ Pinout)
	V _{OUT} (V)	I _{OUT} ② (mA)	R/N (mVp-p) ③		Regulation (Max.)		V _{IN} Nom. (Volts)	Range (Volts)	I _{IN} ⑤ (mA)	Min.	Typ.	
			Typ.	Max.	Line	Load ④						
TWR-5/1200-12/250-D48A	±5	1200	50	100	±1%	±1%	48	18-72	50/340	79%	81%	C4, P8
	±12	±250	75	175	±5%	±5%						
TWR-5/1500-12/250-D48A	±5	1500	50	100	±1%	±1%	48	18-72	50/388	78%	79%	C4, P8
	±12	±250	75	175	±5%	±5%						
TWR-5/1000-15/250-D48A	±5	1000	50	100	±1%	±1%	48	18-72	50/354	79%	80%	C4, P8
	±15	±250	75	175	±5%	±5%						
TWR-5/1500-15/250-D48A	±5	1500	50	100	±1%	±1%	48	18-72	50/425	79%	81%	C4, P8
	±15	±250	75	175	±5%	±5%						

① Typical @ T_A = +25°C under nominal line voltage and full-load conditions unless otherwise noted. ② Ripple/Noise (R/N) measured over a 20MHz bandwidth, specified with 0.2µF ceramic output capacitors. ③ For the +5V output, listed spec applies over the 10% to 100% load range. For the ±12V and ±15V outputs, listed spec applies for balanced loads over the 20% to 100% load range. ④ Nominal line voltage, no-load/full-load conditions.

PART NUMBER STRUCTURE

TWR-5 / 1000-15 / 250-D48 A-C

- T**: Output Configuration: T = Triple
- WR-5**: Wide Range Input
- 1000**: Nominal Primary Output: Voltage (+5V)
- 15**: Maximum Primary Output Current in mA
- 250**: Nominal Auxiliary Output: Voltages (±12 or ±15V)
- D48**: Input Voltage Range: D48 = 18-72V (48V nominal)
- A**: Maximum Auxiliary Output: Currents in mA from each output
- C**: RoHS-6 Compliant*
A Series High Reliability

* Contact Murata Power Solutions Technologies for availability.

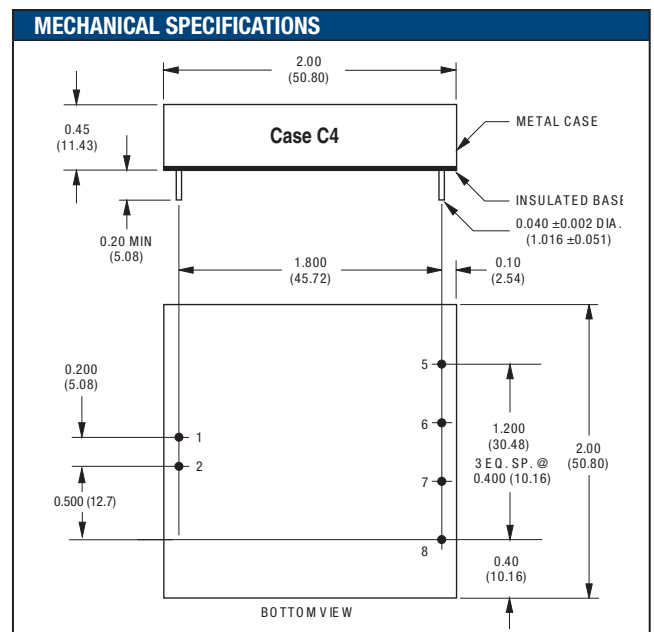
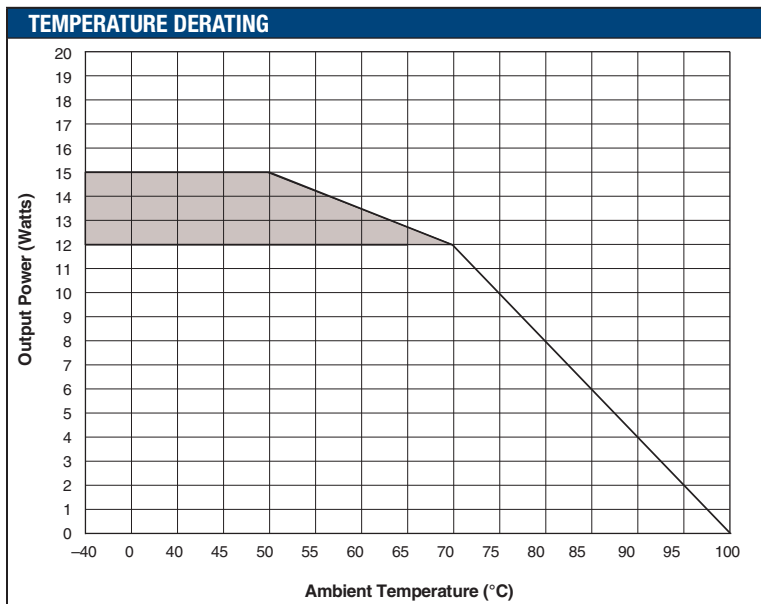

Note: The case is connected to pin 1 (+V_{IN}).

INPUT/OUTPUT CONNECTIONS	
Pin	Function P8
1	+Input
2	-Input
3	No Pin
4	No Pin
5	+12V/15V Output
6	+5V Output
7	Common
8	-12V/15V Output

Dimensions are in inches (mm)

Performance/Functional Specifications

Typical @ T_A = +25°C under nominal line voltage and full-load conditions, unless noted. ①

Input	
Input Voltage Range	18-72 Volts (48V nominal)
Input Current	See Ordering Guide
Input Filter Type ②	Pi
Reverse-Polarity Protection	Yes (Instantaneous, 6A maximum)
Output	
V_{OUT} Accuracy (50% loads):	
+5V Output	±1%
±12V or ±15V Outputs	±3%
Temperature Coefficient	±0.02% per °C
Ripple/Noise (20MHz BW) ②	See Ordering Guide
Line/Load Regulation	See Ordering Guide
Efficiency	See Ordering Guide
Isolation Voltage ③	1500Vdc, minimum
Isolation Capacitance	680pF
Current Limiting	Auto-recovery
Overvoltage Protection	Zener/transorb clamps, magnetic feed back
Dynamic Characteristics	
Transient Response (50% load step)	200µsec max. to ±2% of final value
Switching Frequency	165kHz (±15kHz)
Environmental	
Operating Temperature (ambient):	
Without Derating	-40 to +50-70°C (Model dependent)
With Derating	to +100°C (See Derating Curve)
Storage Temperature	-40 to +105°C
Physical	
Dimensions	2" x 2" x 0.45" (51 x 51 x 11.4mm)
Shielding	5-sided
Case Connection	Pin 1 (+V _{IN})
Case Material	Corrosion resistant steel with non-conductive, epoxy-based, black enamel finish and plastic baseplate
Pin Material	Gold plate copper alloy with nickel underplate
Weight	2.6 ounces (74 grams)

- ① These power converters require a minimum 10% loading on their primary output and a minimum 20% loading on their auxiliary outputs to maintain specified regulation. Operation under no-load conditions will not damage these devices; however they may not meet all listed specifications.
- ② Application-specific internal input/output filtering can be recommended and perhaps added internally upon request. Contact Murata Power Solutions Applications Engineering for details.
- ③ Devices can be screened or modified for higher guaranteed isolation voltages. Contact Murata Power Solutions Applications Engineering for details.

Absolute Maximum Ratings

Input Voltage:	80 Volts
Input Reverse-Polarity Protection	Current must be <6A. Brief duration only. Fusing recommended.
Output Overvoltage Protection	
+5V Output	6.8 Volts, limited duration
±12V Outputs	±13 Volts, limited duration
±15V Outputs	±16 Volts, limited duration
Output Current	Current limited. Max. current and short-circuit duration are model dependent
Storage Temperature	-40 to +105°C
Lead Temperature (soldering, 10 sec.)	+300°C

These are stress ratings. Exposure of devices to any of these conditions may adversely affect long-term reliability. Proper operation under conditions other than those listed in the Performance/Functional Specifications Table is not implied.

TECHNICAL NOTES

Filtering and Noise Reduction

All TWR A-Series 12-15 Watt DC/DC Converters achieve their rated ripple and noise specifications without the use of external input/output capacitors. In critical applications, input/output ripple and noise may be further reduced by installing electrolytic capacitors across the input terminals and/or low-ESR tantalum or electrolytic capacitors across the output terminals. Output capacitors should be connected between their respective output pin (pin 5, 6 or 8) and Common (pin 7) as shown in Figure 2. The caps should be located as close to the power converters as possible. Typical values are listed below. In many applications, using values greater than those listed will yield better results.

To Reduce Input Ripple 10µF, 100V

To Reduce Output Ripple

+5V Output 47µF, 10V, Low ESR
 ±12/15V Outputs 22µF, 20V, Low ESR

In critical, space-sensitive applications, Murata Power Solutions may be able to tailor the internal input/output filtering of these units to meet your specific requirements. Contact our Applications Engineering Group for additional details.

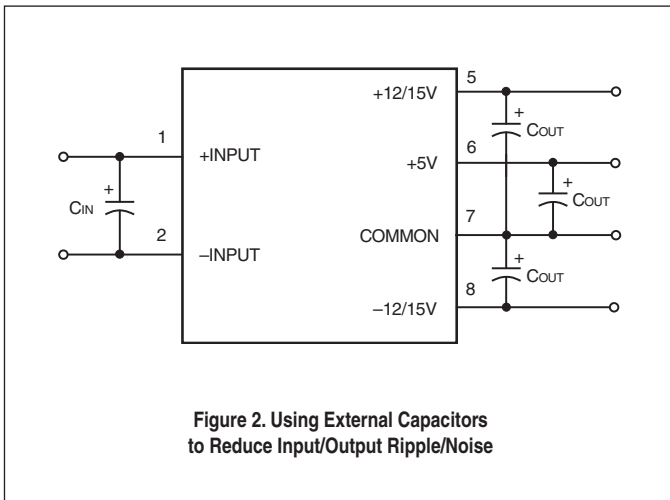

Input Fusing

Certain applications and/or safety agencies may require the installation of fuses at the inputs of power conversion components. For Murata Power Solutions A-Series TWR 12-15 Watt DC/DC Converters, you should use slow-blow type fuses with values no greater than 2A.

CUSTOM CAPABILITIES

Murata Power Solutions' world-class design, development and manufacturing team stands ready to work with you to deliver the exact power converter you need for your demanding, large volume, OEM applications. And . . . we'll do it on time and within budget!

Our experienced applications and design staffs; quick-turn prototype capability; highly automated, SMT assembly facilities; and in-line SPC quality-control techniques combine to give us the unique ability to design and deliver any quantity of power converters to the highest standards of quality and reliability.

We have compiled a large library of DC/DC designs that are currently used in a variety of telecom, medical, computer, railway, aerospace and industrial applications. We may already have the converter you need.

Contact us. Our goal is to provide you the highest-quality, most cost-effective power converters available.

EMI RADIATED EMISSIONS

If you're designing with EMC in mind, please note that all of Murata Power Solutions' TWR A-Series 12-15 Watt DC/DC Converters have been characterized for radiated and conducted emissions in our new EMI/EMC laboratory. Testing is conducted in an EMCO 5305 GTEM test cell utilizing EMCO automated EMC test software. Radiated emissions are tested to the limits of FCC Part 15, Class B and CISPR 22 (EN 55022), Class B. Correlation to other specifications can be supplied upon request. Radiated emissions plots to FCC and CISPR 22 for model TWR-5/1500-15/250-D48A appear below. Published EMC test reports are available for each model number. Contact Murata Power Solutions' Applications Engineering Department for more details.

**TWR-5/1500-15/250-D48A Radiated Emissions
FCC Part 15 Class B 3 Meters
Converter Output = +5Vdc @ 1.35A and ±15Vdc @ 225mA**

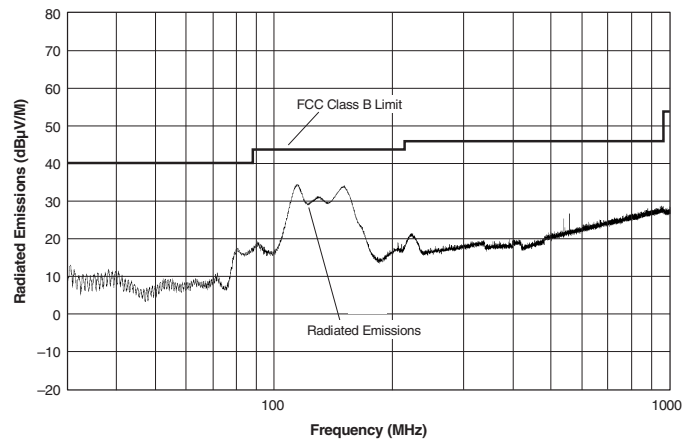

**TWR-5/1500-15/250-D48A Radiated Emissions
EN55022 Class B 10 Meters
Converter Output = +5Vdc @ 1.35A and ±15Vdc @ 225mA**

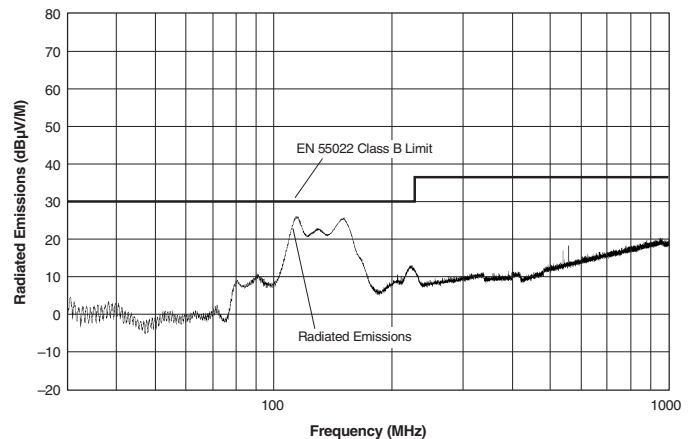

Quality and Reliability

The A-Series are the first DC/DC Converters to emerge from Murata Power Solutions' new, company-wide approach to designing and manufacturing the most reliable power converters available. The five-pronged program draws our Quality Assurance function into all aspects of new-product design, development, characterization, qualification and manufacturing.

Design for Reliability

Design for Reliability is woven throughout our multi-phased, new-product-development process. Design-for-reliability practices are fully documented and begin early in the new-product development cycle with the following goals:

1. To work from an approved components/vendors list ensuring the use of reliable components and the rigorous qualification of new components.
2. To design with safety margins by adhering to a strict set of derating guidelines and performing theoretical worst-case analyses.
3. To locate potential design weaknesses early in the product-development cycle by using extensive HALT (Highly Accelerated Life Testing).

4. To prove that early design improvements are effective by employing a thorough FRACA (Failure Reporting Analysis and Corrective Action) system.

HALT Testing

The goal of the accelerated-stress techniques used by Murata Power Solutions is to force device maturity, in a short period of time, by exposing devices to excessive levels of "every stimulus of potential value." We use HALT (Highly Accelerated Life Testing) repeatedly during the design and early manufacturing phases to detect potential electrical and mechanical design weaknesses that could result in possible future field failures.

During HALT, prototype and pre-production DC/DC converters are subjected to progressively higher stress levels induced by thermal cycling, rate of temperature change, vibration, power cycling, product-specific stresses (such as dc voltage variation) and combined environments. The stresses are not meant to simulate field environments but to expose any weaknesses in a product's electro/mechanical design and/or assembly processes. The goal of HALT is to make products fail so that device weaknesses can be analyzed and strengthened as appropriate. Applied stresses are continually stepped up until products eventually fail. After corrective actions and/or design changes, stresses are stepped up again and the cycle is repeated until the "fundamental limit of the technology" is determined.

Murata Power Solutions has invested in a Qualmark OVS-1 HALT tester

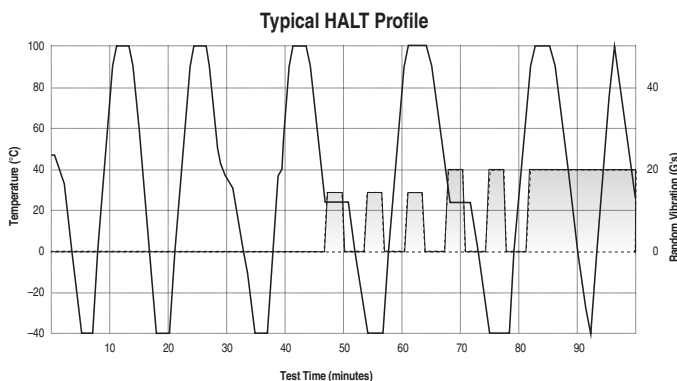

capable of applying voltage and temperature extremes as well as 6-axis, linear and rotational, random vibration. A typical HALT profile (shown above) consists of thermal cycling (-55 to +125°C, 30°C/minute) and simultaneous, gradually increasing, random longitudinal and rotational vibration up to 20Gs with load cycling and applied-voltage extremes added as desired. Many devices in Murata Power Solutions' A-Series could not be made to fail prior to reaching either the limits of the HALT chamber or some previously known

physical limit of the device. We also use the HALT chamber and its ability to rapidly cool devices to verify their "cold-start" capabilities.

Qualification

For each new product, electrical performance is verified via a comprehensive characterization process and long-term reliability is confirmed via a rigorous qualification procedure. The qual procedure includes such strenuous tests as thermal shock and 500 hour life. Qual testing is summarized below.

Qualification Testing

Qualification Test	Method/Comments
HALT	Murata Power Solutions in-house procedure
High Temperature Storage	Max. rated temp., 1,000 hours
Thermal Shock	10 cycles, -55 to +125°C
Temperature/Humidity	+85°C, 85% humidity, 48 hours
Lead Integrity	Murata Power Solutions in-house procedure
Life Test	+70°C, 500 hours*
Marking Permanency	Murata Power Solutions in-house procedure
End Point Electrical Tests	Per product specification

* Interim electrical test at 200 hours.

In-Line Process Controls and Screening

A combination of statistical sampling and 100% inspection techniques keeps our assembly line under constant control. Parameters such as solder-paste thickness, component placement, cleanliness, etc. are statistically sampled, charted and fine tuned as necessary. Visual inspections are performed by trained operators after pick-and-place, soldering and cleaning operations. Units are 100% electrically tested prior to potting. All devices are temperature cycled, burned-in, hi-pot tested and final-electrical tested prior to external visual examination, packing and shipping.

Rapid Response to Problems

Murata Power Solutions employs an outstanding corrective-action system to immediately address any detected shortcomings in either products or processes. Whenever our assembly, quality or engineering personnel spot a product/process problem, or if a product is returned with a potential defect, we immediately perform a detailed failure analysis and, if necessary, undertake corrective actions. Over time, this system has helped refine our assembly operation to yield one of the lowest product defect rates in the industry.